

# International Journal of Engineering Sciences & Research Technology

(A Peer Reviewed Online Journal)  
Impact Factor: 5.164



**Chief Editor**  
**Dr. J.B. Helonde**

**Executive Editor**  
**Mr. Somil Mayur Shah**

As Internet of Things (IoT) devices become more common and edge computing applications expand to accommodate them, many industries are thinking of ways to make the best use of this technology. Health care systems stands immensely from the expand use of IoT devices and edge computing. The people in need of healthcare services find it very expensive this is particularly true in developing countries. With improvement in technology previously expensive hospital equipment has been redesigned using current technology. The main objective of the project was to design a patient health care monitoring system and transfer and process the result to the doctor by using IoT and edge computing .The first part being detection of blood pressure, heartbeat, and body temperature. Second part is transferring this detected data to the internet by using wifi-module and the last part is the android application for Remote viewing of the data enables a doctor or health specialist. Recent technology trend has seen Smart watches, fitness trackers and Smart phones with portable heartbeat detectors. All these are commonly referred to as wearable technology.

**KEYWORDS:** Edge Computing, IoT, wearable technology, health care monitoring.

## 1. INTRODUCTION

A heart beat detection and patient monitoring system using IoT is an extension of a hospital medical system where a patient's vital body state can be monitored remotely. Traditionally the detection systems were only found in hospitals and were characterized by huge and complex circuitry which required high power consumption. Continuous advances in the semiconductor technology industry have led to sensors and microcontrollers that are smaller in size, faster in operation, low in power consumption and affordable in cost. This has further seen development in the remote monitoring of vital life signs of patients especially the elderly. The remote health monitoring system can be applied in the following scenarios:

- i) A patient is known to have a medical condition with unstable regulatory body system. This is in cases where a new drug is being introduced to a patient.
- ii) A patient is prone to heart attacks or may have suffered one before. The vitals may be monitored to predict and alert in advance any indication of the body status.
- iii) Critical body organ situation
- iv) Situation leading to development of a risky life threatening condition. This is for people at an advanced age and may be having failing health conditions.

In recent times several systems have come up to address the issue of remote health monitoring. The systems have a wireless detection system that sends the sensor information wirelessly to a remote server. Some have even adopted a service model that requires one to pay a subscription fee. In developing countries this is a hindrance as some people cannot use them due to cost issue involved. There is also the issue of internet connectivity where some systems to operate good quality internet for a real-time remote connection is required. Internet penetration is still a problem in developing countries. This remote patient monitoring system can provide useful physiological information in the home. This monitoring is useful for elderly or chronically ill patients who would like to avoid a long hospital stay. Sensors are used to collect and transmit signals of interest and a processor is programmed to receive and automatically analyze the sensor signals. In this project you are to choose appropriate sensors according to what you would like to detect and design algorithms to realize your detection.

Using a single parameter monitoring system an approach to a remote health monitoring system was designed that extends healthcare from the traditional clinic or hospital setting to the patient's home. The system was to collect a heartbeat detection system data and a fall detection system data. The data from the two single parameter monitoring systems was then availed for remote detection.

During design the following characteristics of the future medical applications were adhered to:

- a) Integration with current trends in medical practices and technology.
- b) Real-time, long-term, remote monitoring, miniature, wearable sensors. Long battery life of designed device.
- c) Assistance to the elderly and chronic patients. The device should be easy to use with minimal buttons.

Edge computing alleviates this pressure by pushing data processing away from a centralized core and distributing it among local edge data centers and other devices closer to the source. Analyzing data closer to where it's collected provides huge benefits in terms of cost and efficiency. By utilizing edge computing, companies can also address problems associated with low connectivity and the cost of transferring data to a centralized server.

## 2. SYSTEM DESCRIPTION

The block diagram of the proposed system is shown in fig.1. The heart rate and blood pressure is sensed by using a smart wrist band and the temperature is sensed by using a temperature sensor LM 35. this sensors and smart band is connected to a PIC microcontroller. The value from the microcontroller is given to the web server using wifi-connectivity. The parameter value can be viewed by the android application installed in doctors and in the relatives. The proposed system also consist a emergency button it used during the emergency situation. The buzzer is for the notification to the patient and relative. The LCD is used to show the measurement and the notifications from the doctor.

This simple system consists of

- a) PIC microcontroller
- b) WIFI- Module.
- c) Temperature sensor
- d) LCD display
- e) Smart band
- f) Buzzer

### a) *PIC microcontroller*

The PIC18F46K22 is a PIC family microcontroller from Microchip Company. It has 64Kbytes of Flash memory and 1024 bytes of EEPROM. The key element of the PIC18F46K22 microcontroller is Low-control because of proficient XLP innovation joined and provides high performance hence best suited microcontroller for embedded applications. PIC18F46K22 is 40pin plastic dual-in-line package. The main feature is high performance RISC CPU, Adaptable oscillator structure, and Extreme low power management with XLP.

### b) *WIFI-Module*

ESP8266EX delivers highly integrated Wi-Fi SoC solution to meet users. Continuous demands for efficient power usage, compact design and reliable performance in the Internet of Things industry. With the complete and self-contained Wi-Fi networking capabilities, ESP8266EX can perform either as a standalone application or as the slave to a host MCU. When ESP8266EX hosts the application, it promptly boots up from the flash. The integrated high speed cache helps to increase the system performance and optimize the system memory. Also, ESP8266EX can be applied to any micro-controller design as a Wi-Fi adaptor through SPI / SDIO or I2C / UART interfaces.

### c) *Temperature Sensor*

It is an IC sensor that is used to measure temperature with an output voltage linearly proportional to the Centigrade temperature. The LM35 sensor has an advantage over linear temperature sensor, as the user has not to make the conversion of Kelvin to Centigrade. This is major significance of LM-35 that it calibrates directly in Celsius and it is also suitable for remote applications. It has better efficiency than thermistor.

### d) *LCD Display*

A liquid-crystal display (LCD) is a flat panel display, electronic visual display, or video display that uses the light modulating properties of liquid crystals. Liquid crystals do not emit light directly. Here we use LCD display to display the due date.

e) **Buzzer**

A buzzer or beeper is an audio signaling device, be mechanical, electromechanical, or piezoelectric. Typical uses of buzzers and beepers include alarm devices, timers and confirmation of user input such as a mouse click or keystroke.

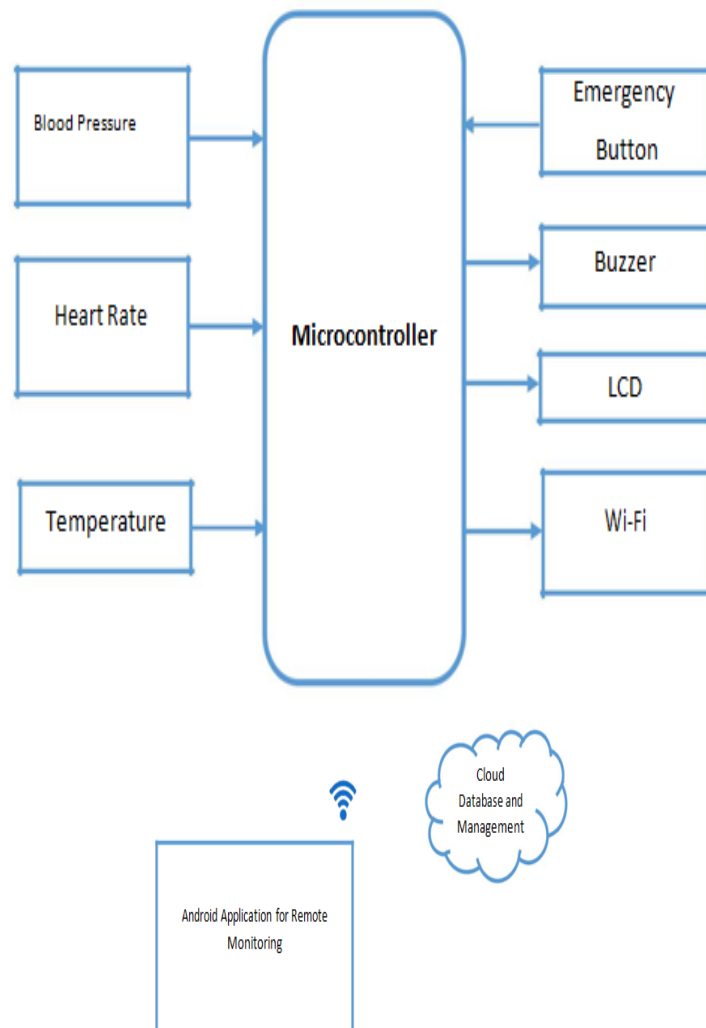

**Fig.1. Block Diagram of the model**

The system which we proposed have the quality of detecting health monitoring with the help of monitoring heart rate and blood pressure and temperature based on internet of things. User will be wearing a device. This system is something like wearable device which can be placed on once wrist so which contains a sensor helps to monitor the heart rate and even blood pressure and using these scenarios we can detect health condition. The sensor is a built in device. When the device is placed on wrist it records the data i.e.; pulse rate so that it monitors the heart beat. The device also has the sensor which records the blood pressure using the pulse rate, peak systolic pressure and baseline systolic pressure. At first we have to record the default values(the values denotes the critical situation) for pulse rate, peak systolic pressure, baseline systolic pressure in the sensor so that the application records the user's activity and checks the collected data of the user with the default values

whether it is near to it or not. When the recorded heart beat i.e.; pulse wave and pressure are in the critical state, then an alert message is sent to doctor's mobile and doctor can suggest first aid for patient. The figure 2 below shows the flow chart description of the health care monitoring system

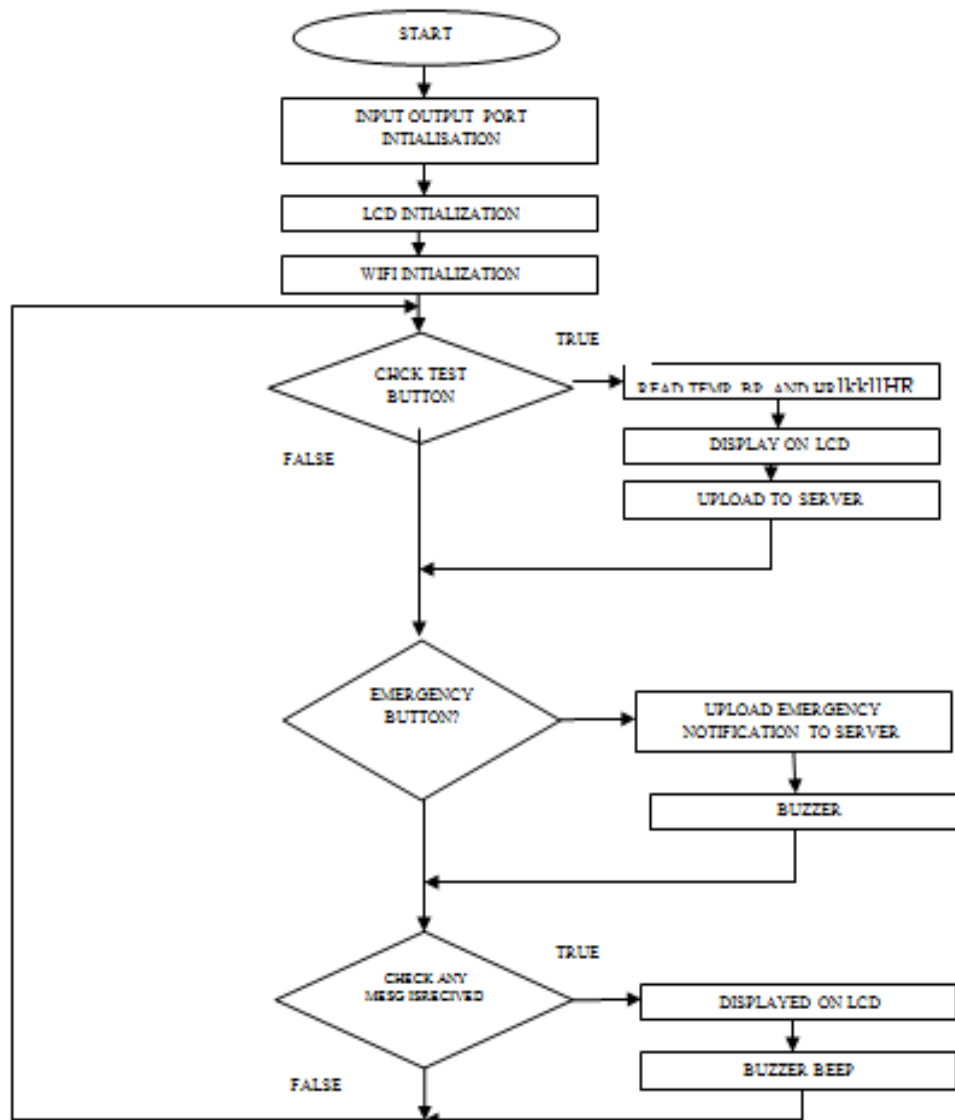

Fig.2. Flow Chart Description

### 3. EDGE COMPUTING IN HEALTH CARE

#### a) Rural Medicine

Providing quality healthcare to isolated rural areas has been a challenge throughout history. Even today, with innovations in telemedicine and more readily accessible health data, medical providers have struggled to deliver fast, quality care to people who live far from hospitals and have limited internet access. Traditional healthcare databases face significant challenges here due to connectivity issues, but the combination of IoT devices and edge computing applications can make it easier to overcome these difficulties.

Portable IoT devices developed by edge computing companies have the ability to gather, store, generate, and analyze critical patient data without needing to be in constant contact with a network infrastructure. Patients

with wearable medical devices can be diagnosed quickly and effectively on-site, and the information gathered from them can be fed back into the central servers whenever connections are reestablished. By interfacing with an edge data center, IoT devices can extend the reach of existing networks, enabling medical personnel to access critical patient data even in areas with poor connectivity. This is just one of the edge computing use cases that has the potential to greatly expand the reach of healthcare services.

#### b) Patient Generated Health Data

A range of IoT devices such as wearable sensors, blood glucose monitors, and healthcare apps have become far more common over the last decade, all of them collecting massive amounts of Patient Generated Health Data (PGHD) that makes it possible for medical professionals to better diagnose problems and monitor patient health over long periods of time. Or rather, these devices create the potential for improved outcomes.

The massive amount of data being produced by these devices may be valuable, but it's also creating a challenge for the healthcare providers tasked with managing it. Much of this data is unstructured and poorly defined, flooding into cloud infrastructures that are often not prepared to run the powerful analytics programs needed to organize it in ways that can be easily utilized. By the time data generated by IoT devices is fed back into a central server to be properly analyzed and sorted, it may be too late to respond to sudden changes in a person's condition.

Edge computing applications have the potential to solve this data problem. By retaining much of the critical processing tasks on the devices located on the edge of the network, healthcare IT architectures can still gain the benefit of gathering health-related data while also getting the rapid, real-time analytics that can predict and respond to health emergencies. Healthcare IoT devices can analyze a person's current condition and send alerts the moment anomalies are detected, allowing for rapid response times that may well save their life. In the meantime, the device can continue to feed non-critical data gathered over time to be sorted and processed by the network's more powerful central servers or data centers operated by edge computing companies.

#### c) Improved Patient Experience

Going to the hospital doesn't have to be an unpleasant or frustrating experience. From smart devices that allow people to check in for appointments whenever they like, to notifications that guide them through an unfamiliar facility to find the proper office, IoT devices are among the key edge computing use cases that have the potential to completely transform the healthcare industry's customer experience.

With so many devices providing assistance to patients and making their experience more convenient and accommodating, edge computing companies will play a far more integral role in healthcare IT infrastructures. Many hospitals have taken to offering streaming content services to patients, providing everything from movies and games to interactive educational programs. Edge data centers can help decentralize this content and make it available more widely with minimal latency.

#### d) Supply Chain

One of the more exciting edge computing use cases involves industry supply chains. Today's hospitals and healthcare centers are technological marvels, filled with cutting edge medical devices and computer hardware used to provide the very best care possible. They're also stocked with less sophisticated, but no less important, medical equipment used in everyday procedures to save lives. Keeping these facilities running is a massive logistical task. From expensive mechanical components for robotic-assisted surgery tools to the smallest bandage, any disruption to the supply chain that keeps them running creates significant risks to health outcomes. Sensor-equipped IoT devices have the potential to revolutionize the way medical facilities manage their inventories. Devices gathering data on usage patterns can utilize predictive analytics to determine when hardware is likely to fail while inventory management based on smart RFID tags can eliminate time consuming paperwork and manual ordering. Fleet vehicles equipped with GPS and other sensors can track the location of critical shipments in real-time. For organizations struggling to control rising costs, IoT supply chain innovations offer an opportunity to gain operational efficiencies on the margins and represent one of the more compelling edge computing use cases.

#### e) Cost Savings

Speaking of cost savings, analysts predict that the widespread adoption of IoT devices can help health care organizations save up to 25% of their business costs. Some of these savings will come from day-to-day applications like security and surveillance or smart building controls, but the real innovation could come from

patient monitoring and engagement. Wearable devices, implantable sensors, and streamlined services based on big data analytics are among the edge computing use cases that could significantly reduce per patient costs across the care continuum.

Interconnectivity is another potential source of cost savings. Medical providers have long been plagued by incompatible systems and burdensome recordkeeping that could be all but eliminated by networks of IoT devices and edge computing applications that communicate quickly and easily across organizational boundaries. With rising costs posing an ongoing threat to people's access to healthcare services, any innovations that could help boost efficiencies and deliver better value are sure to be embraced quickly.

While IoT devices are already becoming quite common, they have yet to scratch the surface of their full potential. As the quantity of devices continues to increase and place additional burdens on network data infrastructures, edge computing examples will soon be found throughout medical IT strategies. The healthcare industry stands to benefit immensely from both developments, and the one-two punch of IoT and edge computing is sure to deliver key advantages in the future.

#### 4. RESULT AND DISCUSSIONS

As health care services are important part of our society, automating these services lessen the burden on humans and eases the measuring process. Also the transparency of this system helps patients to trust it. When threshold value is reached, the alarm system that consists of buzzer and MSG alerts the doctors and he can act more quickly. The objective of developing monitoring systems is to reduce health care costs by reducing physician office visits, hospitalizations, and diagnostic testing procedure. The IoT technology helps the server to update the patient data on website. Many further improvements can be made in our system to make it better and easily adaptable such as adding more advanced sensors. The biometric information of the patient which is stored and published online can be given to scientists and researchers of medical fields to analyse the value and find patterns or for other research work. To simplify the hardware and reduce wiring we can use wireless sensors.

#### 5. CONCLUSION

In these days we have an increased number of heart diseases including increased risk of heart attacks. Our proposed system uses sensors that allow to detect heart rate of a person using heartbeat sensing even if the person is at home. The sensor is then interfaced to a microcontroller that allows checking heart rate readings and transmitting them over internet. The user may set the high as well as low levels of heart beat limit. After setting these limits, the system starts monitoring and as soon as patient heart beat goes above a certain limit, the system sends an alert to the controller which then transmits this over the internet and alerts the doctors as well as concerned users. Also the system alerts for lower heartbeats. Whenever the user logs on for monitoring, the system also displays the live heart rate of the patient. Thus concerned ones may monitor heart rate as well get an alert of heart attack to the patient immediately from anywhere and the person can be saved on time. In our proposed research, we tried to propose a complete paper for detecting heart attack using two ways. However, we have some plan about this research, Times of India, a leading newspaper in India published that "Researchers in the United States, within the next decade Heart Microeconomic Microchip will be set in blood vessel of human body. The smart phone will collect data and send the information to us". Researchers are trying to implement the requirements of Microchip for uses of the technology in smart phone. We will try to use this technology in future.

#### REFERENCES

- [1] K. Navya, Dr. M. B. R. Murthy, "A Zigbee Based Patient HealthMonitoring System", Int. Journal of Engineering Research andApplications Vol. 3, Issue 5, Sep-Oct 2013, pp.483-486
- [2] Matthew D'Souza, Montserrat Ros, Adam Postula, "Wireless MedicalInformation System Network for Patient ECG Monitoring" DigitalSystemDesign:Architectures, Methods and Tools, 2006, DSD 2006, 9th EUROMICRO Conference, 2006, pp.617-624.
- [3] C.C.Gavimath, Krishnamurthy Bhat, C.L. Chayalakshmi , R. S. HooliandB.E.Ravishankera, "Design and Development of versatile salineflow rate measuring system and GSM based remote monitoring device",International Journal of Pharmaceutical Applications ISSN 0976-2639.Vol 3, Issue 1,2012, pp 277-281.
- [4] NakulPadhye and Preet Jain, "Implementation of ARM Embedded WebServer for DAS using Raspberry pi", VSRD IJEECE April 2013 .

- 
- [5] Ch. Sandeep Kumar Subudhi and S. Sivanandam, "Intelligent Wireless Patient Monitoring and Tracking System(Using Sensor Network and Wireless Communication)", International Journal of Interdisciplinary and Multidisciplinary Studies, 2014, Vol 1, No.3, 97-104